

TYPE:

ORDERING CODE:

APPROVAL:

JOB:

LNS-100A/225

DATE:

SPECIFICATIONS

Max Overall Dimensions: 3.543" (OD) x 1.772" (H) (90mm x 45mm)
 Trim / Flange Dimensions: 3.543" (OD) x 0.551" (H) (90mm x 14mm)
 Aperture Diameter: 2.205" (OD) (56mm)
 Rough-in / Cut out: 2.008" (51mm)
 Recess: 0.945" (24mm) excluding fiber
 Primary Material: Plastic
 Lens Type: Comes with fresnel lens or optional broadcast lens (B11458)
 Fiber Type: Recommended FSPT 12-75 max
 Order part LNS-225 for 225 fiber max
 Finishes: Black, White
 Ferrule Requirement: Special ferrule included
 Mounting: Conduit, stubbing to 1.5" PVC, Lens tightening tool FS-117 (pg 102) required for installation
 Notes: IP68, Underwater rated

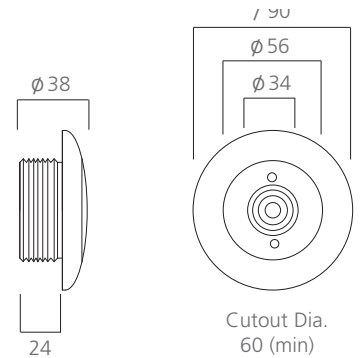

TYPE:

ORDERING CODE:

APPROVAL:

JOB:

DATE:

SPECIFICATIONS

TYPE:

ORDERING CODE:

APPROVAL:

JOB:

DATE:

SPECIFICATIONS